

ESPLOSO RICAMBI SCALDACQUA ELETTRICI AD ACCUMULO

Modello

SI -SLIM V

R8215223-02IT - Edizione 02 - 02/02/2006



380 0000		SI-SLIM 30 V 1,5 KW
506 441		SI-50 V
380 0001		SI-SLIM 50 V 1,5 KW
506 691		SI-50 V 2KW
380 0002		SI-SLIM 65 V 1,5 KW
506 443		SI-80 V
380 0003		SI-SLIM 80 V 1,5 KW
506 692		SI-80 V 2KW
506 445		SI-100 V
506 693		SI-100 V 2KW
506 749		SI-120 V 2,5KW
506 750		SI-150 V 2,5KW
Codice	Ind.	Modello	Date inizio	Data fine

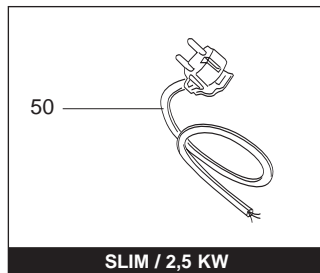
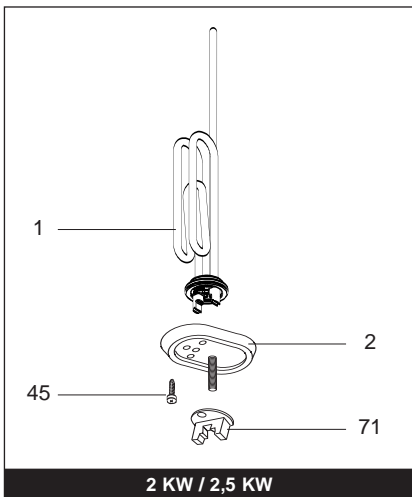
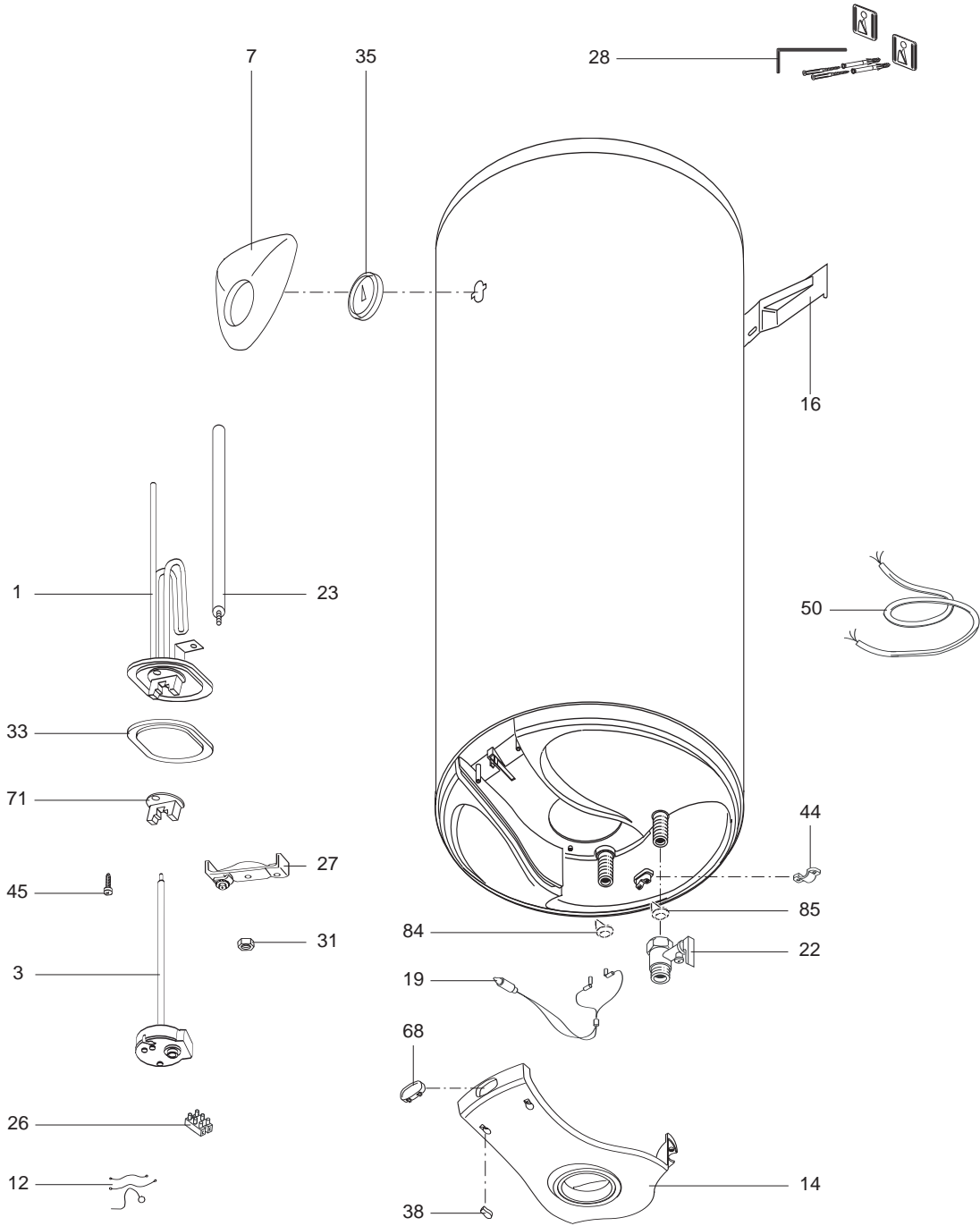

Rifer. figura	Descrizione	Codice	Altra	Tipo													Data																																																																																																																																																																																																																																																																																																																																																																																																																																																																																																																																																																																																																																																																																																																																																																																																																																																																					
					30		50		65		80		100		120		150		da	a																																																																																																																																																																																																																																																																																																																																																																																																																																																																																																																																																																																																																																																																																																																																																																																																																																																																		
					Slim	2kw	Slim	2kw	Slim	2kw	Slim	2kw	Slim	2kw	Slim	2kw	Slim	2kw																																																																																																																																																																																																																																																																																																																																																																																																																																																																																																																																																																																																																																																																																																																																																																																																																																																																				
0001	RESISTENZA 1500W 230V	65160202			•		•		•		•		•		•		•			RESISTENZA 1500W 230V	816600				•			•			•			•					RESISTENZA 2000W 230V	993209					•			•			•			•				RESISTENZA 2500W 230V	816606									•			•			•		0002	FLANGIA AUTOCLAVICA CON GUARN.INTEGRALE	65103691					•			•			•		•		•			FLANGIA AUTOCLAVICA CON GUARN.INTEGRALE	65103691				•			•			•			•			10/05		FLANGIA AUTOCLAVICA CON GUARN.INTEGRALE	993012				•			•			•			•			09/05	0003	TERMOSTATO	65100311				•			•			•			•			09/05		TERMOSTATO	65101041					•			•			•			•				TERMOSTATO	691217												•		•				TERMOSTATO	691217				•			•			•			•			10/05		TERMOSTATO	691256				•		•	•		•								0007	SUPPORTO TERMOMETRO	65160211				•		•	•		•								0012	CABLAGGIO (KIT)	508200				•			•			•						09/05	0014	CALOTTINA	502389				•			•			•						09/05		CALOTTINA	65160157					•			•			•		•		•			CALOTTINA	65160157				•			•			•						10/05		CALOTTINA	65160207				•		•	•		•								0016	STAFFA INSTALLAZIONE	502419				•		•	•		•		•		•		•		0018	MANOPOLA REGOLAZIONE	502391				•		•	•		•		•		•		•		0019	LAMPADA SPIA	993025				•		•	•		•		•		•		•		0022	VALVOLA SICUREZZA CON LEVA	571730				•		•	•		•		•		•		•		0023	ANODO DI MAGNESIO	65103326				•		•	•		•								0026	CONNECTOR	508331				•			•			•						09/05	0027	STAFFA SERRA FLANGIA	502383				•		•	•		•		•		•		•			STAFFA SERRA FLANGIA	570339				•		•	•		•		•		•		•		0028	VITI E TASSELLI	502379				•		•	•		•		•		•		•		0031	DADO ESAGONALE	570127				•		•	•		•		•		•		•		0033	GUARNIZIONE FLANGIA	570340				•		•	•		•								0035	TERMOMETRO	65160210				•		•	•		•									TERMOMETRO	976188						•	•			•		•		•				TERMOMETRO	976188					•		•			•						10/05	0038	TAPPO COPRIVITE	502394				•		•	•		•							09/05		TAPPO COPRIVITE	502394				•		•	•		•									TAPPO COPRIVITE	65160108						•	•			•		•		•				TAPPO COPRIVITE	65160108						•	•			•		•				10/05	0044	FERMACAVO	573266				•		•	•		•		•		•		•		0045	VITE M6X12	993000				•		•	•		•		•		•		•		0050	CAVO ALIMENTAZIONE	993199				•		•	•		•		•		•		•			CAVO ALIMENTAZIONE	570086						•	•			•								CAVO ALIMENTAZIONE	570086						•	•			•						10/05	0068	GEMMA SPIA	976002				•		•	•		•		•		•		•		0071	PROTEZIONE FASTON ROSSO	993010				•		•	•		•		•		•		•		0084	BORCHIA TUBO USCITA ROSSA	502386						•	•			•						09/05	0085	BORCHIA TUBO ENTRATA BLU	502387						•	•			•						09/05
	RESISTENZA 1500W 230V	816600				•			•			•			•					RESISTENZA 2000W 230V	993209					•			•			•			•				RESISTENZA 2500W 230V	816606									•			•			•		0002	FLANGIA AUTOCLAVICA CON GUARN.INTEGRALE	65103691					•			•			•		•		•			FLANGIA AUTOCLAVICA CON GUARN.INTEGRALE	65103691				•			•			•			•			10/05		FLANGIA AUTOCLAVICA CON GUARN.INTEGRALE	993012				•			•			•			•			09/05	0003	TERMOSTATO	65100311				•			•			•			•			09/05		TERMOSTATO	65101041					•			•			•			•				TERMOSTATO	691217												•		•				TERMOSTATO	691217				•			•			•			•			10/05		TERMOSTATO	691256				•		•	•		•								0007	SUPPORTO TERMOMETRO	65160211				•		•	•		•								0012	CABLAGGIO (KIT)	508200				•			•			•						09/05	0014	CALOTTINA	502389				•			•			•						09/05		CALOTTINA	65160157					•			•			•		•		•			CALOTTINA	65160157				•			•			•						10/05		CALOTTINA	65160207				•		•	•		•								0016	STAFFA INSTALLAZIONE	502419				•		•	•		•		•		•		•		0018	MANOPOLA REGOLAZIONE	502391				•		•	•		•		•		•		•		0019	LAMPADA SPIA	993025				•		•	•		•		•		•		•		0022	VALVOLA SICUREZZA CON LEVA	571730				•		•	•		•		•		•		•		0023	ANODO DI MAGNESIO	65103326				•		•	•		•								0026	CONNECTOR	508331				•			•			•						09/05	0027	STAFFA SERRA FLANGIA	502383				•		•	•		•		•		•		•			STAFFA SERRA FLANGIA	570339				•		•	•		•		•		•		•		0028	VITI E TASSELLI	502379				•		•	•		•		•		•		•		0031	DADO ESAGONALE	570127				•		•	•		•		•		•		•		0033	GUARNIZIONE FLANGIA	570340				•		•	•		•								0035	TERMOMETRO	65160210				•		•	•		•									TERMOMETRO	976188						•	•			•		•		•				TERMOMETRO	976188					•		•			•						10/05	0038	TAPPO COPRIVITE	502394				•		•	•		•							09/05		TAPPO COPRIVITE	502394				•		•	•		•									TAPPO COPRIVITE	65160108						•	•			•		•		•				TAPPO COPRIVITE	65160108						•	•			•		•				10/05	0044	FERMACAVO	573266				•		•	•		•		•		•		•		0045	VITE M6X12	993000				•		•	•		•		•		•		•		0050	CAVO ALIMENTAZIONE	993199				•		•	•		•		•		•		•			CAVO ALIMENTAZIONE	570086						•	•			•								CAVO ALIMENTAZIONE	570086						•	•			•						10/05	0068	GEMMA SPIA	976002				•		•	•		•		•		•		•		0071	PROTEZIONE FASTON ROSSO	993010				•		•	•		•		•		•		•		0084	BORCHIA TUBO USCITA ROSSA	502386						•	•			•						09/05	0085	BORCHIA TUBO ENTRATA BLU	502387						•	•			•						09/05																			
	RESISTENZA 2000W 230V	993209					•			•			•			•				RESISTENZA 2500W 230V	816606									•			•			•		0002	FLANGIA AUTOCLAVICA CON GUARN.INTEGRALE	65103691					•			•			•		•		•			FLANGIA AUTOCLAVICA CON GUARN.INTEGRALE	65103691				•			•			•			•			10/05		FLANGIA AUTOCLAVICA CON GUARN.INTEGRALE	993012				•			•			•			•			09/05	0003	TERMOSTATO	65100311				•			•			•			•			09/05		TERMOSTATO	65101041					•			•			•			•				TERMOSTATO	691217												•		•				TERMOSTATO	691217				•			•			•			•			10/05		TERMOSTATO	691256				•		•	•		•								0007	SUPPORTO TERMOMETRO	65160211				•		•	•		•								0012	CABLAGGIO (KIT)	508200				•			•			•						09/05	0014	CALOTTINA	502389				•			•			•						09/05		CALOTTINA	65160157					•			•			•		•		•			CALOTTINA	65160157				•			•			•						10/05		CALOTTINA	65160207				•		•	•		•								0016	STAFFA INSTALLAZIONE	502419				•		•	•		•		•		•		•		0018	MANOPOLA REGOLAZIONE	502391				•		•	•		•		•		•		•		0019	LAMPADA SPIA	993025				•		•	•		•		•		•		•		0022	VALVOLA SICUREZZA CON LEVA	571730				•		•	•		•		•		•		•		0023	ANODO DI MAGNESIO	65103326				•		•	•		•								0026	CONNECTOR	508331				•			•			•						09/05	0027	STAFFA SERRA FLANGIA	502383				•		•	•		•		•		•		•			STAFFA SERRA FLANGIA	570339				•		•	•		•		•		•		•		0028	VITI E TASSELLI	502379				•		•	•		•		•		•		•		0031	DADO ESAGONALE	570127				•		•	•		•		•		•		•		0033	GUARNIZIONE FLANGIA	570340				•		•	•		•								0035	TERMOMETRO	65160210				•		•	•		•									TERMOMETRO	976188						•	•			•		•		•				TERMOMETRO	976188					•		•			•						10/05	0038	TAPPO COPRIVITE	502394				•		•	•		•							09/05		TAPPO COPRIVITE	502394				•		•	•		•									TAPPO COPRIVITE	65160108						•	•			•		•		•				TAPPO COPRIVITE	65160108						•	•			•		•				10/05	0044	FERMACAVO	573266				•		•	•		•		•		•		•		0045	VITE M6X12	993000				•		•	•		•		•		•		•		0050	CAVO ALIMENTAZIONE	993199				•		•	•		•		•		•		•			CAVO ALIMENTAZIONE	570086						•	•			•								CAVO ALIMENTAZIONE	570086						•	•			•						10/05	0068	GEMMA SPIA	976002				•		•	•		•		•		•		•		0071	PROTEZIONE FASTON ROSSO	993010				•		•	•		•		•		•		•		0084	BORCHIA TUBO USCITA ROSSA	502386						•	•			•						09/05	0085	BORCHIA TUBO ENTRATA BLU	502387						•	•			•						09/05																																						
	RESISTENZA 2500W 230V	816606									•			•			•		0002	FLANGIA AUTOCLAVICA CON GUARN.INTEGRALE	65103691					•			•			•		•		•			FLANGIA AUTOCLAVICA CON GUARN.INTEGRALE	65103691				•			•			•			•			10/05		FLANGIA AUTOCLAVICA CON GUARN.INTEGRALE	993012				•			•			•			•			09/05	0003	TERMOSTATO	65100311				•			•			•			•			09/05		TERMOSTATO	65101041					•			•			•			•				TERMOSTATO	691217												•		•				TERMOSTATO	691217				•			•			•			•			10/05		TERMOSTATO	691256				•		•	•		•								0007	SUPPORTO TERMOMETRO	65160211				•		•	•		•								0012	CABLAGGIO (KIT)	508200				•			•			•						09/05	0014	CALOTTINA	502389				•			•			•						09/05		CALOTTINA	65160157					•			•			•		•		•			CALOTTINA	65160157				•			•			•						10/05		CALOTTINA	65160207				•		•	•		•								0016	STAFFA INSTALLAZIONE	502419				•		•	•		•		•		•		•		0018	MANOPOLA REGOLAZIONE	502391				•		•	•		•		•		•		•		0019	LAMPADA SPIA	993025				•		•	•		•		•		•		•		0022	VALVOLA SICUREZZA CON LEVA	571730				•		•	•		•		•		•		•		0023	ANODO DI MAGNESIO	65103326				•		•	•		•								0026	CONNECTOR	508331				•			•			•						09/05	0027	STAFFA SERRA FLANGIA	502383				•		•	•		•		•		•		•			STAFFA SERRA FLANGIA	570339				•		•	•		•		•		•		•		0028	VITI E TASSELLI	502379				•		•	•		•		•		•		•		0031	DADO ESAGONALE	570127				•		•	•		•		•		•		•		0033	GUARNIZIONE FLANGIA	570340				•		•	•		•								0035	TERMOMETRO	65160210				•		•	•		•									TERMOMETRO	976188						•	•			•		•		•				TERMOMETRO	976188					•		•			•						10/05	0038	TAPPO COPRIVITE	502394				•		•	•		•							09/05		TAPPO COPRIVITE	502394				•		•	•		•									TAPPO COPRIVITE	65160108						•	•			•		•		•				TAPPO COPRIVITE	65160108						•	•			•		•				10/05	0044	FERMACAVO	573266				•		•	•		•		•		•		•		0045	VITE M6X12	993000				•		•	•		•		•		•		•		0050	CAVO ALIMENTAZIONE	993199				•		•	•		•		•		•		•			CAVO ALIMENTAZIONE	570086						•	•			•								CAVO ALIMENTAZIONE	570086						•	•			•						10/05	0068	GEMMA SPIA	976002				•		•	•		•		•		•		•		0071	PROTEZIONE FASTON ROSSO	993010				•		•	•		•		•		•		•		0084	BORCHIA TUBO USCITA ROSSA	502386						•	•			•						09/05	0085	BORCHIA TUBO ENTRATA BLU	502387						•	•			•						09/05																																																									
0002	FLANGIA AUTOCLAVICA CON GUARN.INTEGRALE	65103691					•			•			•		•		•			FLANGIA AUTOCLAVICA CON GUARN.INTEGRALE	65103691				•			•			•			•			10/05		FLANGIA AUTOCLAVICA CON GUARN.INTEGRALE	993012				•			•			•			•			09/05	0003	TERMOSTATO	65100311				•			•			•			•			09/05		TERMOSTATO	65101041					•			•			•			•				TERMOSTATO	691217												•		•				TERMOSTATO	691217				•			•			•			•			10/05		TERMOSTATO	691256				•		•	•		•								0007	SUPPORTO TERMOMETRO	65160211				•		•	•		•								0012	CABLAGGIO (KIT)	508200				•			•			•						09/05	0014	CALOTTINA	502389				•			•			•						09/05		CALOTTINA	65160157					•			•			•		•		•			CALOTTINA	65160157				•			•			•						10/05		CALOTTINA	65160207				•		•	•		•								0016	STAFFA INSTALLAZIONE	502419				•		•	•		•		•		•		•		0018	MANOPOLA REGOLAZIONE	502391				•		•	•		•		•		•		•		0019	LAMPADA SPIA	993025				•		•	•		•		•		•		•		0022	VALVOLA SICUREZZA CON LEVA	571730				•		•	•		•		•		•		•		0023	ANODO DI MAGNESIO	65103326				•		•	•		•								0026	CONNECTOR	508331				•			•			•						09/05	0027	STAFFA SERRA FLANGIA	502383				•		•	•		•		•		•		•			STAFFA SERRA FLANGIA	570339				•		•	•		•		•		•		•		0028	VITI E TASSELLI	502379				•		•	•		•		•		•		•		0031	DADO ESAGONALE	570127				•		•	•		•		•		•		•		0033	GUARNIZIONE FLANGIA	570340				•		•	•		•								0035	TERMOMETRO	65160210				•		•	•		•									TERMOMETRO	976188						•	•			•		•		•				TERMOMETRO	976188					•		•			•						10/05	0038	TAPPO COPRIVITE	502394				•		•	•		•							09/05		TAPPO COPRIVITE	502394				•		•	•		•									TAPPO COPRIVITE	65160108						•	•			•		•		•				TAPPO COPRIVITE	65160108						•	•			•		•				10/05	0044	FERMACAVO	573266				•		•	•		•		•		•		•		0045	VITE M6X12	993000				•		•	•		•		•		•		•		0050	CAVO ALIMENTAZIONE	993199				•		•	•		•		•		•		•			CAVO ALIMENTAZIONE	570086						•	•			•								CAVO ALIMENTAZIONE	570086						•	•			•						10/05	0068	GEMMA SPIA	976002				•		•	•		•		•		•		•		0071	PROTEZIONE FASTON ROSSO	993010				•		•	•		•		•		•		•		0084	BORCHIA TUBO USCITA ROSSA	502386						•	•			•						09/05	0085	BORCHIA TUBO ENTRATA BLU	502387						•	•			•						09/05																																																																												
	FLANGIA AUTOCLAVICA CON GUARN.INTEGRALE	65103691				•			•			•			•			10/05		FLANGIA AUTOCLAVICA CON GUARN.INTEGRALE	993012				•			•			•			•			09/05	0003	TERMOSTATO	65100311				•			•			•			•			09/05		TERMOSTATO	65101041					•			•			•			•				TERMOSTATO	691217												•		•				TERMOSTATO	691217				•			•			•			•			10/05		TERMOSTATO	691256				•		•	•		•								0007	SUPPORTO TERMOMETRO	65160211				•		•	•		•								0012	CABLAGGIO (KIT)	508200				•			•			•						09/05	0014	CALOTTINA	502389				•			•			•						09/05		CALOTTINA	65160157					•			•			•		•		•			CALOTTINA	65160157				•			•			•						10/05		CALOTTINA	65160207				•		•	•		•								0016	STAFFA INSTALLAZIONE	502419				•		•	•		•		•		•		•		0018	MANOPOLA REGOLAZIONE	502391				•		•	•		•		•		•		•		0019	LAMPADA SPIA	993025				•		•	•		•		•		•		•		0022	VALVOLA SICUREZZA CON LEVA	571730				•		•	•		•		•		•		•		0023	ANODO DI MAGNESIO	65103326				•		•	•		•								0026	CONNECTOR	508331				•			•			•						09/05	0027	STAFFA SERRA FLANGIA	502383				•		•	•		•		•		•		•			STAFFA SERRA FLANGIA	570339				•		•	•		•		•		•		•		0028	VITI E TASSELLI	502379				•		•	•		•		•		•		•		0031	DADO ESAGONALE	570127				•		•	•		•		•		•		•		0033	GUARNIZIONE FLANGIA	570340				•		•	•		•								0035	TERMOMETRO	65160210				•		•	•		•									TERMOMETRO	976188						•	•			•		•		•				TERMOMETRO	976188					•		•			•						10/05	0038	TAPPO COPRIVITE	502394				•		•	•		•							09/05		TAPPO COPRIVITE	502394				•		•	•		•									TAPPO COPRIVITE	65160108						•	•			•		•		•				TAPPO COPRIVITE	65160108						•	•			•		•				10/05	0044	FERMACAVO	573266				•		•	•		•		•		•		•		0045	VITE M6X12	993000				•		•	•		•		•		•		•		0050	CAVO ALIMENTAZIONE	993199				•		•	•		•		•		•		•			CAVO ALIMENTAZIONE	570086						•	•			•								CAVO ALIMENTAZIONE	570086						•	•			•						10/05	0068	GEMMA SPIA	976002				•		•	•		•		•		•		•		0071	PROTEZIONE FASTON ROSSO	993010				•		•	•		•		•		•		•		0084	BORCHIA TUBO USCITA ROSSA	502386						•	•			•						09/05	0085	BORCHIA TUBO ENTRATA BLU	502387						•	•			•						09/05																																																																																															
	FLANGIA AUTOCLAVICA CON GUARN.INTEGRALE	993012				•			•			•			•			09/05	0003	TERMOSTATO	65100311				•			•			•			•			09/05		TERMOSTATO	65101041					•			•			•			•				TERMOSTATO	691217												•		•				TERMOSTATO	691217				•			•			•			•			10/05		TERMOSTATO	691256				•		•	•		•								0007	SUPPORTO TERMOMETRO	65160211				•		•	•		•								0012	CABLAGGIO (KIT)	508200				•			•			•						09/05	0014	CALOTTINA	502389				•			•			•						09/05		CALOTTINA	65160157					•			•			•		•		•			CALOTTINA	65160157				•			•			•						10/05		CALOTTINA	65160207				•		•	•		•								0016	STAFFA INSTALLAZIONE	502419				•		•	•		•		•		•		•		0018	MANOPOLA REGOLAZIONE	502391				•		•	•		•		•		•		•		0019	LAMPADA SPIA	993025				•		•	•		•		•		•		•		0022	VALVOLA SICUREZZA CON LEVA	571730				•		•	•		•		•		•		•		0023	ANODO DI MAGNESIO	65103326				•		•	•		•								0026	CONNECTOR	508331				•			•			•						09/05	0027	STAFFA SERRA FLANGIA	502383				•		•	•		•		•		•		•			STAFFA SERRA FLANGIA	570339				•		•	•		•		•		•		•		0028	VITI E TASSELLI	502379				•		•	•		•		•		•		•		0031	DADO ESAGONALE	570127				•		•	•		•		•		•		•		0033	GUARNIZIONE FLANGIA	570340				•		•	•		•								0035	TERMOMETRO	65160210				•		•	•		•									TERMOMETRO	976188						•	•			•		•		•				TERMOMETRO	976188					•		•			•						10/05	0038	TAPPO COPRIVITE	502394				•		•	•		•							09/05		TAPPO COPRIVITE	502394				•		•	•		•									TAPPO COPRIVITE	65160108						•	•			•		•		•				TAPPO COPRIVITE	65160108						•	•			•		•				10/05	0044	FERMACAVO	573266				•		•	•		•		•		•		•		0045	VITE M6X12	993000				•		•	•		•		•		•		•		0050	CAVO ALIMENTAZIONE	993199				•		•	•		•		•		•		•			CAVO ALIMENTAZIONE	570086						•	•			•								CAVO ALIMENTAZIONE	570086						•	•			•						10/05	0068	GEMMA SPIA	976002				•		•	•		•		•		•		•		0071	PROTEZIONE FASTON ROSSO	993010				•		•	•		•		•		•		•		0084	BORCHIA TUBO USCITA ROSSA	502386						•	•			•						09/05	0085	BORCHIA TUBO ENTRATA BLU	502387						•	•			•						09/05																																																																																																																		
0003	TERMOSTATO	65100311				•			•			•			•			09/05		TERMOSTATO	65101041					•			•			•			•				TERMOSTATO	691217												•		•				TERMOSTATO	691217				•			•			•			•			10/05		TERMOSTATO	691256				•		•	•		•								0007	SUPPORTO TERMOMETRO	65160211				•		•	•		•								0012	CABLAGGIO (KIT)	508200				•			•			•						09/05	0014	CALOTTINA	502389				•			•			•						09/05		CALOTTINA	65160157					•			•			•		•		•			CALOTTINA	65160157				•			•			•						10/05		CALOTTINA	65160207				•		•	•		•								0016	STAFFA INSTALLAZIONE	502419				•		•	•		•		•		•		•		0018	MANOPOLA REGOLAZIONE	502391				•		•	•		•		•		•		•		0019	LAMPADA SPIA	993025				•		•	•		•		•		•		•		0022	VALVOLA SICUREZZA CON LEVA	571730				•		•	•		•		•		•		•		0023	ANODO DI MAGNESIO	65103326				•		•	•		•								0026	CONNECTOR	508331				•			•			•						09/05	0027	STAFFA SERRA FLANGIA	502383				•		•	•		•		•		•		•			STAFFA SERRA FLANGIA	570339				•		•	•		•		•		•		•		0028	VITI E TASSELLI	502379				•		•	•		•		•		•		•		0031	DADO ESAGONALE	570127				•		•	•		•		•		•		•		0033	GUARNIZIONE FLANGIA	570340				•		•	•		•								0035	TERMOMETRO	65160210				•		•	•		•									TERMOMETRO	976188						•	•			•		•		•				TERMOMETRO	976188					•		•			•						10/05	0038	TAPPO COPRIVITE	502394				•		•	•		•							09/05		TAPPO COPRIVITE	502394				•		•	•		•									TAPPO COPRIVITE	65160108						•	•			•		•		•				TAPPO COPRIVITE	65160108						•	•			•		•				10/05	0044	FERMACAVO	573266				•		•	•		•		•		•		•		0045	VITE M6X12	993000				•		•	•		•		•		•		•		0050	CAVO ALIMENTAZIONE	993199				•		•	•		•		•		•		•			CAVO ALIMENTAZIONE	570086						•	•			•								CAVO ALIMENTAZIONE	570086						•	•			•						10/05	0068	GEMMA SPIA	976002				•		•	•		•		•		•		•		0071	PROTEZIONE FASTON ROSSO	993010				•		•	•		•		•		•		•		0084	BORCHIA TUBO USCITA ROSSA	502386						•	•			•						09/05	0085	BORCHIA TUBO ENTRATA BLU	502387						•	•			•						09/05																																																																																																																																					
	TERMOSTATO	65101041					•			•			•			•				TERMOSTATO	691217												•		•				TERMOSTATO	691217				•			•			•			•			10/05		TERMOSTATO	691256				•		•	•		•								0007	SUPPORTO TERMOMETRO	65160211				•		•	•		•								0012	CABLAGGIO (KIT)	508200				•			•			•						09/05	0014	CALOTTINA	502389				•			•			•						09/05		CALOTTINA	65160157					•			•			•		•		•			CALOTTINA	65160157				•			•			•						10/05		CALOTTINA	65160207				•		•	•		•								0016	STAFFA INSTALLAZIONE	502419				•		•	•		•		•		•		•		0018	MANOPOLA REGOLAZIONE	502391				•		•	•		•		•		•		•		0019	LAMPADA SPIA	993025				•		•	•		•		•		•		•		0022	VALVOLA SICUREZZA CON LEVA	571730				•		•	•		•		•		•		•		0023	ANODO DI MAGNESIO	65103326				•		•	•		•								0026	CONNECTOR	508331				•			•			•						09/05	0027	STAFFA SERRA FLANGIA	502383				•		•	•		•		•		•		•			STAFFA SERRA FLANGIA	570339				•		•	•		•		•		•		•		0028	VITI E TASSELLI	502379				•		•	•		•		•		•		•		0031	DADO ESAGONALE	570127				•		•	•		•		•		•		•		0033	GUARNIZIONE FLANGIA	570340				•		•	•		•								0035	TERMOMETRO	65160210				•		•	•		•									TERMOMETRO	976188						•	•			•		•		•				TERMOMETRO	976188					•		•			•						10/05	0038	TAPPO COPRIVITE	502394				•		•	•		•							09/05		TAPPO COPRIVITE	502394				•		•	•		•									TAPPO COPRIVITE	65160108						•	•			•		•		•				TAPPO COPRIVITE	65160108						•	•			•		•				10/05	0044	FERMACAVO	573266				•		•	•		•		•		•		•		0045	VITE M6X12	993000				•		•	•		•		•		•		•		0050	CAVO ALIMENTAZIONE	993199				•		•	•		•		•		•		•			CAVO ALIMENTAZIONE	570086						•	•			•								CAVO ALIMENTAZIONE	570086						•	•			•						10/05	0068	GEMMA SPIA	976002				•		•	•		•		•		•		•		0071	PROTEZIONE FASTON ROSSO	993010				•		•	•		•		•		•		•		0084	BORCHIA TUBO USCITA ROSSA	502386						•	•			•						09/05	0085	BORCHIA TUBO ENTRATA BLU	502387						•	•			•						09/05																																																																																																																																																								
	TERMOSTATO	691217												•		•				TERMOSTATO	691217				•			•			•			•			10/05		TERMOSTATO	691256				•		•	•		•								0007	SUPPORTO TERMOMETRO	65160211				•		•	•		•								0012	CABLAGGIO (KIT)	508200				•			•			•						09/05	0014	CALOTTINA	502389				•			•			•						09/05		CALOTTINA	65160157					•			•			•		•		•			CALOTTINA	65160157				•			•			•						10/05		CALOTTINA	65160207				•		•	•		•								0016	STAFFA INSTALLAZIONE	502419				•		•	•		•		•		•		•		0018	MANOPOLA REGOLAZIONE	502391				•		•	•		•		•		•		•		0019	LAMPADA SPIA	993025				•		•	•		•		•		•		•		0022	VALVOLA SICUREZZA CON LEVA	571730				•		•	•		•		•		•		•		0023	ANODO DI MAGNESIO	65103326				•		•	•		•								0026	CONNECTOR	508331				•			•			•						09/05	0027	STAFFA SERRA FLANGIA	502383				•		•	•		•		•		•		•			STAFFA SERRA FLANGIA	570339				•		•	•		•		•		•		•		0028	VITI E TASSELLI	502379				•		•	•		•		•		•		•		0031	DADO ESAGONALE	570127				•		•	•		•		•		•		•		0033	GUARNIZIONE FLANGIA	570340				•		•	•		•								0035	TERMOMETRO	65160210				•		•	•		•									TERMOMETRO	976188						•	•			•		•		•				TERMOMETRO	976188					•		•			•						10/05	0038	TAPPO COPRIVITE	502394				•		•	•		•							09/05		TAPPO COPRIVITE	502394				•		•	•		•									TAPPO COPRIVITE	65160108						•	•			•		•		•				TAPPO COPRIVITE	65160108						•	•			•		•				10/05	0044	FERMACAVO	573266				•		•	•		•		•		•		•		0045	VITE M6X12	993000				•		•	•		•		•		•		•		0050	CAVO ALIMENTAZIONE	993199				•		•	•		•		•		•		•			CAVO ALIMENTAZIONE	570086						•	•			•								CAVO ALIMENTAZIONE	570086						•	•			•						10/05	0068	GEMMA SPIA	976002				•		•	•		•		•		•		•		0071	PROTEZIONE FASTON ROSSO	993010				•		•	•		•		•		•		•		0084	BORCHIA TUBO USCITA ROSSA	502386						•	•			•						09/05	0085	BORCHIA TUBO ENTRATA BLU	502387						•	•			•						09/05																																																																																																																																																																											
	TERMOSTATO	691217				•			•			•			•			10/05		TERMOSTATO	691256				•		•	•		•								0007	SUPPORTO TERMOMETRO	65160211				•		•	•		•								0012	CABLAGGIO (KIT)	508200				•			•			•						09/05	0014	CALOTTINA	502389				•			•			•						09/05		CALOTTINA	65160157					•			•			•		•		•			CALOTTINA	65160157				•			•			•						10/05		CALOTTINA	65160207				•		•	•		•								0016	STAFFA INSTALLAZIONE	502419				•		•	•		•		•		•		•		0018	MANOPOLA REGOLAZIONE	502391				•		•	•		•		•		•		•		0019	LAMPADA SPIA	993025				•		•	•		•		•		•		•		0022	VALVOLA SICUREZZA CON LEVA	571730				•		•	•		•		•		•		•		0023	ANODO DI MAGNESIO	65103326				•		•	•		•								0026	CONNECTOR	508331				•			•			•						09/05	0027	STAFFA SERRA FLANGIA	502383				•		•	•		•		•		•		•			STAFFA SERRA FLANGIA	570339				•		•	•		•		•		•		•		0028	VITI E TASSELLI	502379				•		•	•		•		•		•		•		0031	DADO ESAGONALE	570127				•		•	•		•		•		•		•		0033	GUARNIZIONE FLANGIA	570340				•		•	•		•								0035	TERMOMETRO	65160210				•		•	•		•									TERMOMETRO	976188						•	•			•		•		•				TERMOMETRO	976188					•		•			•						10/05	0038	TAPPO COPRIVITE	502394				•		•	•		•							09/05		TAPPO COPRIVITE	502394				•		•	•		•									TAPPO COPRIVITE	65160108						•	•			•		•		•				TAPPO COPRIVITE	65160108						•	•			•		•				10/05	0044	FERMACAVO	573266				•		•	•		•		•		•		•		0045	VITE M6X12	993000				•		•	•		•		•		•		•		0050	CAVO ALIMENTAZIONE	993199				•		•	•		•		•		•		•			CAVO ALIMENTAZIONE	570086						•	•			•								CAVO ALIMENTAZIONE	570086						•	•			•						10/05	0068	GEMMA SPIA	976002				•		•	•		•		•		•		•		0071	PROTEZIONE FASTON ROSSO	993010				•		•	•		•		•		•		•		0084	BORCHIA TUBO USCITA ROSSA	502386						•	•			•						09/05	0085	BORCHIA TUBO ENTRATA BLU	502387						•	•			•						09/05																																																																																																																																																																																														
	TERMOSTATO	691256				•		•	•		•								0007	SUPPORTO TERMOMETRO	65160211				•		•	•		•								0012	CABLAGGIO (KIT)	508200				•			•			•						09/05	0014	CALOTTINA	502389				•			•			•						09/05		CALOTTINA	65160157					•			•			•		•		•			CALOTTINA	65160157				•			•			•						10/05		CALOTTINA	65160207				•		•	•		•								0016	STAFFA INSTALLAZIONE	502419				•		•	•		•		•		•		•		0018	MANOPOLA REGOLAZIONE	502391				•		•	•		•		•		•		•		0019	LAMPADA SPIA	993025				•		•	•		•		•		•		•		0022	VALVOLA SICUREZZA CON LEVA	571730				•		•	•		•		•		•		•		0023	ANODO DI MAGNESIO	65103326				•		•	•		•								0026	CONNECTOR	508331				•			•			•						09/05	0027	STAFFA SERRA FLANGIA	502383				•		•	•		•		•		•		•			STAFFA SERRA FLANGIA	570339				•		•	•		•		•		•		•		0028	VITI E TASSELLI	502379				•		•	•		•		•		•		•		0031	DADO ESAGONALE	570127				•		•	•		•		•		•		•		0033	GUARNIZIONE FLANGIA	570340				•		•	•		•								0035	TERMOMETRO	65160210				•		•	•		•									TERMOMETRO	976188						•	•			•		•		•				TERMOMETRO	976188					•		•			•						10/05	0038	TAPPO COPRIVITE	502394				•		•	•		•							09/05		TAPPO COPRIVITE	502394				•		•	•		•									TAPPO COPRIVITE	65160108						•	•			•		•		•				TAPPO COPRIVITE	65160108						•	•			•		•				10/05	0044	FERMACAVO	573266				•		•	•		•		•		•		•		0045	VITE M6X12	993000				•		•	•		•		•		•		•		0050	CAVO ALIMENTAZIONE	993199				•		•	•		•		•		•		•			CAVO ALIMENTAZIONE	570086						•	•			•								CAVO ALIMENTAZIONE	570086						•	•			•						10/05	0068	GEMMA SPIA	976002				•		•	•		•		•		•		•		0071	PROTEZIONE FASTON ROSSO	993010				•		•	•		•		•		•		•		0084	BORCHIA TUBO USCITA ROSSA	502386						•	•			•						09/05	0085	BORCHIA TUBO ENTRATA BLU	502387						•	•			•						09/05																																																																																																																																																																																																																	
0007	SUPPORTO TERMOMETRO	65160211				•		•	•		•								0012	CABLAGGIO (KIT)	508200				•			•			•						09/05	0014	CALOTTINA	502389				•			•			•						09/05		CALOTTINA	65160157					•			•			•		•		•			CALOTTINA	65160157				•			•			•						10/05		CALOTTINA	65160207				•		•	•		•								0016	STAFFA INSTALLAZIONE	502419				•		•	•		•		•		•		•		0018	MANOPOLA REGOLAZIONE	502391				•		•	•		•		•		•		•		0019	LAMPADA SPIA	993025				•		•	•		•		•		•		•		0022	VALVOLA SICUREZZA CON LEVA	571730				•		•	•		•		•		•		•		0023	ANODO DI MAGNESIO	65103326				•		•	•		•								0026	CONNECTOR	508331				•			•			•						09/05	0027	STAFFA SERRA FLANGIA	502383				•		•	•		•		•		•		•			STAFFA SERRA FLANGIA	570339				•		•	•		•		•		•		•		0028	VITI E TASSELLI	502379				•		•	•		•		•		•		•		0031	DADO ESAGONALE	570127				•		•	•		•		•		•		•		0033	GUARNIZIONE FLANGIA	570340				•		•	•		•								0035	TERMOMETRO	65160210				•		•	•		•									TERMOMETRO	976188						•	•			•		•		•				TERMOMETRO	976188					•		•			•						10/05	0038	TAPPO COPRIVITE	502394				•		•	•		•							09/05		TAPPO COPRIVITE	502394				•		•	•		•									TAPPO COPRIVITE	65160108						•	•			•		•		•				TAPPO COPRIVITE	65160108						•	•			•		•				10/05	0044	FERMACAVO	573266				•		•	•		•		•		•		•		0045	VITE M6X12	993000				•		•	•		•		•		•		•		0050	CAVO ALIMENTAZIONE	993199				•		•	•		•		•		•		•			CAVO ALIMENTAZIONE	570086						•	•			•								CAVO ALIMENTAZIONE	570086						•	•			•						10/05	0068	GEMMA SPIA	976002				•		•	•		•		•		•		•		0071	PROTEZIONE FASTON ROSSO	993010				•		•	•		•		•		•		•		0084	BORCHIA TUBO USCITA ROSSA	502386						•	•			•						09/05	0085	BORCHIA TUBO ENTRATA BLU	502387						•	•			•						09/05																																																																																																																																																																																																																																				
0012	CABLAGGIO (KIT)	508200				•			•			•						09/05	0014	CALOTTINA	502389				•			•			•						09/05		CALOTTINA	65160157					•			•			•		•		•			CALOTTINA	65160157				•			•			•						10/05		CALOTTINA	65160207				•		•	•		•								0016	STAFFA INSTALLAZIONE	502419				•		•	•		•		•		•		•		0018	MANOPOLA REGOLAZIONE	502391				•		•	•		•		•		•		•		0019	LAMPADA SPIA	993025				•		•	•		•		•		•		•		0022	VALVOLA SICUREZZA CON LEVA	571730				•		•	•		•		•		•		•		0023	ANODO DI MAGNESIO	65103326				•		•	•		•								0026	CONNECTOR	508331				•			•			•						09/05	0027	STAFFA SERRA FLANGIA	502383				•		•	•		•		•		•		•			STAFFA SERRA FLANGIA	570339				•		•	•		•		•		•		•		0028	VITI E TASSELLI	502379				•		•	•		•		•		•		•		0031	DADO ESAGONALE	570127				•		•	•		•		•		•		•		0033	GUARNIZIONE FLANGIA	570340				•		•	•		•								0035	TERMOMETRO	65160210				•		•	•		•									TERMOMETRO	976188						•	•			•		•		•				TERMOMETRO	976188					•		•			•						10/05	0038	TAPPO COPRIVITE	502394				•		•	•		•							09/05		TAPPO COPRIVITE	502394				•		•	•		•									TAPPO COPRIVITE	65160108						•	•			•		•		•				TAPPO COPRIVITE	65160108						•	•			•		•				10/05	0044	FERMACAVO	573266				•		•	•		•		•		•		•		0045	VITE M6X12	993000				•		•	•		•		•		•		•		0050	CAVO ALIMENTAZIONE	993199				•		•	•		•		•		•		•			CAVO ALIMENTAZIONE	570086						•	•			•								CAVO ALIMENTAZIONE	570086						•	•			•						10/05	0068	GEMMA SPIA	976002				•		•	•		•		•		•		•		0071	PROTEZIONE FASTON ROSSO	993010				•		•	•		•		•		•		•		0084	BORCHIA TUBO USCITA ROSSA	502386						•	•			•						09/05	0085	BORCHIA TUBO ENTRATA BLU	502387						•	•			•						09/05																																																																																																																																																																																																																																																							
0014	CALOTTINA	502389				•			•			•						09/05		CALOTTINA	65160157					•			•			•		•		•			CALOTTINA	65160157				•			•			•						10/05		CALOTTINA	65160207				•		•	•		•								0016	STAFFA INSTALLAZIONE	502419				•		•	•		•		•		•		•		0018	MANOPOLA REGOLAZIONE	502391				•		•	•		•		•		•		•		0019	LAMPADA SPIA	993025				•		•	•		•		•		•		•		0022	VALVOLA SICUREZZA CON LEVA	571730				•		•	•		•		•		•		•		0023	ANODO DI MAGNESIO	65103326				•		•	•		•								0026	CONNECTOR	508331				•			•			•						09/05	0027	STAFFA SERRA FLANGIA	502383				•		•	•		•		•		•		•			STAFFA SERRA FLANGIA	570339				•		•	•		•		•		•		•		0028	VITI E TASSELLI	502379				•		•	•		•		•		•		•		0031	DADO ESAGONALE	570127				•		•	•		•		•		•		•		0033	GUARNIZIONE FLANGIA	570340				•		•	•		•								0035	TERMOMETRO	65160210				•		•	•		•									TERMOMETRO	976188						•	•			•		•		•				TERMOMETRO	976188					•		•			•						10/05	0038	TAPPO COPRIVITE	502394				•		•	•		•							09/05		TAPPO COPRIVITE	502394				•		•	•		•									TAPPO COPRIVITE	65160108						•	•			•		•		•				TAPPO COPRIVITE	65160108						•	•			•		•				10/05	0044	FERMACAVO	573266				•		•	•		•		•		•		•		0045	VITE M6X12	993000				•		•	•		•		•		•		•		0050	CAVO ALIMENTAZIONE	993199				•		•	•		•		•		•		•			CAVO ALIMENTAZIONE	570086						•	•			•								CAVO ALIMENTAZIONE	570086						•	•			•						10/05	0068	GEMMA SPIA	976002				•		•	•		•		•		•		•		0071	PROTEZIONE FASTON ROSSO	993010				•		•	•		•		•		•		•		0084	BORCHIA TUBO USCITA ROSSA	502386						•	•			•						09/05	0085	BORCHIA TUBO ENTRATA BLU	502387						•	•			•						09/05																																																																																																																																																																																																																																																																										
	CALOTTINA	65160157					•			•			•		•		•			CALOTTINA	65160157				•			•			•						10/05		CALOTTINA	65160207				•		•	•		•								0016	STAFFA INSTALLAZIONE	502419				•		•	•		•		•		•		•		0018	MANOPOLA REGOLAZIONE	502391				•		•	•		•		•		•		•		0019	LAMPADA SPIA	993025				•		•	•		•		•		•		•		0022	VALVOLA SICUREZZA CON LEVA	571730				•		•	•		•		•		•		•		0023	ANODO DI MAGNESIO	65103326				•		•	•		•								0026	CONNECTOR	508331				•			•			•						09/05	0027	STAFFA SERRA FLANGIA	502383				•		•	•		•		•		•		•			STAFFA SERRA FLANGIA	570339				•		•	•		•		•		•		•		0028	VITI E TASSELLI	502379				•		•	•		•		•		•		•		0031	DADO ESAGONALE	570127				•		•	•		•		•		•		•		0033	GUARNIZIONE FLANGIA	570340				•		•	•		•								0035	TERMOMETRO	65160210				•		•	•		•									TERMOMETRO	976188						•	•			•		•		•				TERMOMETRO	976188					•		•			•						10/05	0038	TAPPO COPRIVITE	502394				•		•	•		•							09/05		TAPPO COPRIVITE	502394				•		•	•		•									TAPPO COPRIVITE	65160108						•	•			•		•		•				TAPPO COPRIVITE	65160108						•	•			•		•				10/05	0044	FERMACAVO	573266				•		•	•		•		•		•		•		0045	VITE M6X12	993000				•		•	•		•		•		•		•		0050	CAVO ALIMENTAZIONE	993199				•		•	•		•		•		•		•			CAVO ALIMENTAZIONE	570086						•	•			•								CAVO ALIMENTAZIONE	570086						•	•			•						10/05	0068	GEMMA SPIA	976002				•		•	•		•		•		•		•		0071	PROTEZIONE FASTON ROSSO	993010				•		•	•		•		•		•		•		0084	BORCHIA TUBO USCITA ROSSA	502386						•	•			•						09/05	0085	BORCHIA TUBO ENTRATA BLU	502387						•	•			•						09/05																																																																																																																																																																																																																																																																																													
	CALOTTINA	65160157				•			•			•						10/05		CALOTTINA	65160207				•		•	•		•								0016	STAFFA INSTALLAZIONE	502419				•		•	•		•		•		•		•		0018	MANOPOLA REGOLAZIONE	502391				•		•	•		•		•		•		•		0019	LAMPADA SPIA	993025				•		•	•		•		•		•		•		0022	VALVOLA SICUREZZA CON LEVA	571730				•		•	•		•		•		•		•		0023	ANODO DI MAGNESIO	65103326				•		•	•		•								0026	CONNECTOR	508331				•			•			•						09/05	0027	STAFFA SERRA FLANGIA	502383				•		•	•		•		•		•		•			STAFFA SERRA FLANGIA	570339				•		•	•		•		•		•		•		0028	VITI E TASSELLI	502379				•		•	•		•		•		•		•		0031	DADO ESAGONALE	570127				•		•	•		•		•		•		•		0033	GUARNIZIONE FLANGIA	570340				•		•	•		•								0035	TERMOMETRO	65160210				•		•	•		•									TERMOMETRO	976188						•	•			•		•		•				TERMOMETRO	976188					•		•			•						10/05	0038	TAPPO COPRIVITE	502394				•		•	•		•							09/05		TAPPO COPRIVITE	502394				•		•	•		•									TAPPO COPRIVITE	65160108						•	•			•		•		•				TAPPO COPRIVITE	65160108						•	•			•		•				10/05	0044	FERMACAVO	573266				•		•	•		•		•		•		•		0045	VITE M6X12	993000				•		•	•		•		•		•		•		0050	CAVO ALIMENTAZIONE	993199				•		•	•		•		•		•		•			CAVO ALIMENTAZIONE	570086						•	•			•								CAVO ALIMENTAZIONE	570086						•	•			•						10/05	0068	GEMMA SPIA	976002				•		•	•		•		•		•		•		0071	PROTEZIONE FASTON ROSSO	993010				•		•	•		•		•		•		•		0084	BORCHIA TUBO USCITA ROSSA	502386						•	•			•						09/05	0085	BORCHIA TUBO ENTRATA BLU	502387						•	•			•						09/05																																																																																																																																																																																																																																																																																																																
	CALOTTINA	65160207				•		•	•		•								0016	STAFFA INSTALLAZIONE	502419				•		•	•		•		•		•		•		0018	MANOPOLA REGOLAZIONE	502391				•		•	•		•		•		•		•		0019	LAMPADA SPIA	993025				•		•	•		•		•		•		•		0022	VALVOLA SICUREZZA CON LEVA	571730				•		•	•		•		•		•		•		0023	ANODO DI MAGNESIO	65103326				•		•	•		•								0026	CONNECTOR	508331				•			•			•						09/05	0027	STAFFA SERRA FLANGIA	502383				•		•	•		•		•		•		•			STAFFA SERRA FLANGIA	570339				•		•	•		•		•		•		•		0028	VITI E TASSELLI	502379				•		•	•		•		•		•		•		0031	DADO ESAGONALE	570127				•		•	•		•		•		•		•		0033	GUARNIZIONE FLANGIA	570340				•		•	•		•								0035	TERMOMETRO	65160210				•		•	•		•									TERMOMETRO	976188						•	•			•		•		•				TERMOMETRO	976188					•		•			•						10/05	0038	TAPPO COPRIVITE	502394				•		•	•		•							09/05		TAPPO COPRIVITE	502394				•		•	•		•									TAPPO COPRIVITE	65160108						•	•			•		•		•				TAPPO COPRIVITE	65160108						•	•			•		•				10/05	0044	FERMACAVO	573266				•		•	•		•		•		•		•		0045	VITE M6X12	993000				•		•	•		•		•		•		•		0050	CAVO ALIMENTAZIONE	993199				•		•	•		•		•		•		•			CAVO ALIMENTAZIONE	570086						•	•			•								CAVO ALIMENTAZIONE	570086						•	•			•						10/05	0068	GEMMA SPIA	976002				•		•	•		•		•		•		•		0071	PROTEZIONE FASTON ROSSO	993010				•		•	•		•		•		•		•		0084	BORCHIA TUBO USCITA ROSSA	502386						•	•			•						09/05	0085	BORCHIA TUBO ENTRATA BLU	502387						•	•			•						09/05																																																																																																																																																																																																																																																																																																																																			
0016	STAFFA INSTALLAZIONE	502419				•		•	•		•		•		•		•		0018	MANOPOLA REGOLAZIONE	502391				•		•	•		•		•		•		•		0019	LAMPADA SPIA	993025				•		•	•		•		•		•		•		0022	VALVOLA SICUREZZA CON LEVA	571730				•		•	•		•		•		•		•		0023	ANODO DI MAGNESIO	65103326				•		•	•		•								0026	CONNECTOR	508331				•			•			•						09/05	0027	STAFFA SERRA FLANGIA	502383				•		•	•		•		•		•		•			STAFFA SERRA FLANGIA	570339				•		•	•		•		•		•		•		0028	VITI E TASSELLI	502379				•		•	•		•		•		•		•		0031	DADO ESAGONALE	570127				•		•	•		•		•		•		•		0033	GUARNIZIONE FLANGIA	570340				•		•	•		•								0035	TERMOMETRO	65160210				•		•	•		•									TERMOMETRO	976188						•	•			•		•		•				TERMOMETRO	976188					•		•			•						10/05	0038	TAPPO COPRIVITE	502394				•		•	•		•							09/05		TAPPO COPRIVITE	502394				•		•	•		•									TAPPO COPRIVITE	65160108						•	•			•		•		•				TAPPO COPRIVITE	65160108						•	•			•		•				10/05	0044	FERMACAVO	573266				•		•	•		•		•		•		•		0045	VITE M6X12	993000				•		•	•		•		•		•		•		0050	CAVO ALIMENTAZIONE	993199				•		•	•		•		•		•		•			CAVO ALIMENTAZIONE	570086						•	•			•								CAVO ALIMENTAZIONE	570086						•	•			•						10/05	0068	GEMMA SPIA	976002				•		•	•		•		•		•		•		0071	PROTEZIONE FASTON ROSSO	993010				•		•	•		•		•		•		•		0084	BORCHIA TUBO USCITA ROSSA	502386						•	•			•						09/05	0085	BORCHIA TUBO ENTRATA BLU	502387						•	•			•						09/05																																																																																																																																																																																																																																																																																																																																																						
0018	MANOPOLA REGOLAZIONE	502391				•		•	•		•		•		•		•		0019	LAMPADA SPIA	993025				•		•	•		•		•		•		•		0022	VALVOLA SICUREZZA CON LEVA	571730				•		•	•		•		•		•		•		0023	ANODO DI MAGNESIO	65103326				•		•	•		•								0026	CONNECTOR	508331				•			•			•						09/05	0027	STAFFA SERRA FLANGIA	502383				•		•	•		•		•		•		•			STAFFA SERRA FLANGIA	570339				•		•	•		•		•		•		•		0028	VITI E TASSELLI	502379				•		•	•		•		•		•		•		0031	DADO ESAGONALE	570127				•		•	•		•		•		•		•		0033	GUARNIZIONE FLANGIA	570340				•		•	•		•								0035	TERMOMETRO	65160210				•		•	•		•									TERMOMETRO	976188						•	•			•		•		•				TERMOMETRO	976188					•		•			•						10/05	0038	TAPPO COPRIVITE	502394				•		•	•		•							09/05		TAPPO COPRIVITE	502394				•		•	•		•									TAPPO COPRIVITE	65160108						•	•			•		•		•				TAPPO COPRIVITE	65160108						•	•			•		•				10/05	0044	FERMACAVO	573266				•		•	•		•		•		•		•		0045	VITE M6X12	993000				•		•	•		•		•		•		•		0050	CAVO ALIMENTAZIONE	993199				•		•	•		•		•		•		•			CAVO ALIMENTAZIONE	570086						•	•			•								CAVO ALIMENTAZIONE	570086						•	•			•						10/05	0068	GEMMA SPIA	976002				•		•	•		•		•		•		•		0071	PROTEZIONE FASTON ROSSO	993010				•		•	•		•		•		•		•		0084	BORCHIA TUBO USCITA ROSSA	502386						•	•			•						09/05	0085	BORCHIA TUBO ENTRATA BLU	502387						•	•			•						09/05																																																																																																																																																																																																																																																																																																																																																																									
0019	LAMPADA SPIA	993025				•		•	•		•		•		•		•		0022	VALVOLA SICUREZZA CON LEVA	571730				•		•	•		•		•		•		•		0023	ANODO DI MAGNESIO	65103326				•		•	•		•								0026	CONNECTOR	508331				•			•			•						09/05	0027	STAFFA SERRA FLANGIA	502383				•		•	•		•		•		•		•			STAFFA SERRA FLANGIA	570339				•		•	•		•		•		•		•		0028	VITI E TASSELLI	502379				•		•	•		•		•		•		•		0031	DADO ESAGONALE	570127				•		•	•		•		•		•		•		0033	GUARNIZIONE FLANGIA	570340				•		•	•		•								0035	TERMOMETRO	65160210				•		•	•		•									TERMOMETRO	976188						•	•			•		•		•				TERMOMETRO	976188					•		•			•						10/05	0038	TAPPO COPRIVITE	502394				•		•	•		•							09/05		TAPPO COPRIVITE	502394				•		•	•		•									TAPPO COPRIVITE	65160108						•	•			•		•		•				TAPPO COPRIVITE	65160108						•	•			•		•				10/05	0044	FERMACAVO	573266				•		•	•		•		•		•		•		0045	VITE M6X12	993000				•		•	•		•		•		•		•		0050	CAVO ALIMENTAZIONE	993199				•		•	•		•		•		•		•			CAVO ALIMENTAZIONE	570086						•	•			•								CAVO ALIMENTAZIONE	570086						•	•			•						10/05	0068	GEMMA SPIA	976002				•		•	•		•		•		•		•		0071	PROTEZIONE FASTON ROSSO	993010				•		•	•		•		•		•		•		0084	BORCHIA TUBO USCITA ROSSA	502386						•	•			•						09/05	0085	BORCHIA TUBO ENTRATA BLU	502387						•	•			•						09/05																																																																																																																																																																																																																																																																																																																																																																																												
0022	VALVOLA SICUREZZA CON LEVA	571730				•		•	•		•		•		•		•		0023	ANODO DI MAGNESIO	65103326				•		•	•		•								0026	CONNECTOR	508331				•			•			•						09/05	0027	STAFFA SERRA FLANGIA	502383				•		•	•		•		•		•		•			STAFFA SERRA FLANGIA	570339				•		•	•		•		•		•		•		0028	VITI E TASSELLI	502379				•		•	•		•		•		•		•		0031	DADO ESAGONALE	570127				•		•	•		•		•		•		•		0033	GUARNIZIONE FLANGIA	570340				•		•	•		•								0035	TERMOMETRO	65160210				•		•	•		•									TERMOMETRO	976188						•	•			•		•		•				TERMOMETRO	976188					•		•			•						10/05	0038	TAPPO COPRIVITE	502394				•		•	•		•							09/05		TAPPO COPRIVITE	502394				•		•	•		•									TAPPO COPRIVITE	65160108						•	•			•		•		•				TAPPO COPRIVITE	65160108						•	•			•		•				10/05	0044	FERMACAVO	573266				•		•	•		•		•		•		•		0045	VITE M6X12	993000				•		•	•		•		•		•		•		0050	CAVO ALIMENTAZIONE	993199				•		•	•		•		•		•		•			CAVO ALIMENTAZIONE	570086						•	•			•								CAVO ALIMENTAZIONE	570086						•	•			•						10/05	0068	GEMMA SPIA	976002				•		•	•		•		•		•		•		0071	PROTEZIONE FASTON ROSSO	993010				•		•	•		•		•		•		•		0084	BORCHIA TUBO USCITA ROSSA	502386						•	•			•						09/05	0085	BORCHIA TUBO ENTRATA BLU	502387						•	•			•						09/05																																																																																																																																																																																																																																																																																																																																																																																																															
0023	ANODO DI MAGNESIO	65103326				•		•	•		•								0026	CONNECTOR	508331				•			•			•						09/05	0027	STAFFA SERRA FLANGIA	502383				•		•	•		•		•		•		•			STAFFA SERRA FLANGIA	570339				•		•	•		•		•		•		•		0028	VITI E TASSELLI	502379				•		•	•		•		•		•		•		0031	DADO ESAGONALE	570127				•		•	•		•		•		•		•		0033	GUARNIZIONE FLANGIA	570340				•		•	•		•								0035	TERMOMETRO	65160210				•		•	•		•									TERMOMETRO	976188						•	•			•		•		•				TERMOMETRO	976188					•		•			•						10/05	0038	TAPPO COPRIVITE	502394				•		•	•		•							09/05		TAPPO COPRIVITE	502394				•		•	•		•									TAPPO COPRIVITE	65160108						•	•			•		•		•				TAPPO COPRIVITE	65160108						•	•			•		•				10/05	0044	FERMACAVO	573266				•		•	•		•		•		•		•		0045	VITE M6X12	993000				•		•	•		•		•		•		•		0050	CAVO ALIMENTAZIONE	993199				•		•	•		•		•		•		•			CAVO ALIMENTAZIONE	570086						•	•			•								CAVO ALIMENTAZIONE	570086						•	•			•						10/05	0068	GEMMA SPIA	976002				•		•	•		•		•		•		•		0071	PROTEZIONE FASTON ROSSO	993010				•		•	•		•		•		•		•		0084	BORCHIA TUBO USCITA ROSSA	502386						•	•			•						09/05	0085	BORCHIA TUBO ENTRATA BLU	502387						•	•			•						09/05																																																																																																																																																																																																																																																																																																																																																																																																																																		
0026	CONNECTOR	508331				•			•			•						09/05	0027	STAFFA SERRA FLANGIA	502383				•		•	•		•		•		•		•			STAFFA SERRA FLANGIA	570339				•		•	•		•		•		•		•		0028	VITI E TASSELLI	502379				•		•	•		•		•		•		•		0031	DADO ESAGONALE	570127				•		•	•		•		•		•		•		0033	GUARNIZIONE FLANGIA	570340				•		•	•		•								0035	TERMOMETRO	65160210				•		•	•		•									TERMOMETRO	976188						•	•			•		•		•				TERMOMETRO	976188					•		•			•						10/05	0038	TAPPO COPRIVITE	502394				•		•	•		•							09/05		TAPPO COPRIVITE	502394				•		•	•		•									TAPPO COPRIVITE	65160108						•	•			•		•		•				TAPPO COPRIVITE	65160108						•	•			•		•				10/05	0044	FERMACAVO	573266				•		•	•		•		•		•		•		0045	VITE M6X12	993000				•		•	•		•		•		•		•		0050	CAVO ALIMENTAZIONE	993199				•		•	•		•		•		•		•			CAVO ALIMENTAZIONE	570086						•	•			•								CAVO ALIMENTAZIONE	570086						•	•			•						10/05	0068	GEMMA SPIA	976002				•		•	•		•		•		•		•		0071	PROTEZIONE FASTON ROSSO	993010				•		•	•		•		•		•		•		0084	BORCHIA TUBO USCITA ROSSA	502386						•	•			•						09/05	0085	BORCHIA TUBO ENTRATA BLU	502387						•	•			•						09/05																																																																																																																																																																																																																																																																																																																																																																																																																																																					
0027	STAFFA SERRA FLANGIA	502383				•		•	•		•		•		•		•			STAFFA SERRA FLANGIA	570339				•		•	•		•		•		•		•		0028	VITI E TASSELLI	502379				•		•	•		•		•		•		•		0031	DADO ESAGONALE	570127				•		•	•		•		•		•		•		0033	GUARNIZIONE FLANGIA	570340				•		•	•		•								0035	TERMOMETRO	65160210				•		•	•		•									TERMOMETRO	976188						•	•			•		•		•				TERMOMETRO	976188					•		•			•						10/05	0038	TAPPO COPRIVITE	502394				•		•	•		•							09/05		TAPPO COPRIVITE	502394				•		•	•		•									TAPPO COPRIVITE	65160108						•	•			•		•		•				TAPPO COPRIVITE	65160108						•	•			•		•				10/05	0044	FERMACAVO	573266				•		•	•		•		•		•		•		0045	VITE M6X12	993000				•		•	•		•		•		•		•		0050	CAVO ALIMENTAZIONE	993199				•		•	•		•		•		•		•			CAVO ALIMENTAZIONE	570086						•	•			•								CAVO ALIMENTAZIONE	570086						•	•			•						10/05	0068	GEMMA SPIA	976002				•		•	•		•		•		•		•		0071	PROTEZIONE FASTON ROSSO	993010				•		•	•		•		•		•		•		0084	BORCHIA TUBO USCITA ROSSA	502386						•	•			•						09/05	0085	BORCHIA TUBO ENTRATA BLU	502387						•	•			•						09/05																																																																																																																																																																																																																																																																																																																																																																																																																																																																								
	STAFFA SERRA FLANGIA	570339				•		•	•		•		•		•		•		0028	VITI E TASSELLI	502379				•		•	•		•		•		•		•		0031	DADO ESAGONALE	570127				•		•	•		•		•		•		•		0033	GUARNIZIONE FLANGIA	570340				•		•	•		•								0035	TERMOMETRO	65160210				•		•	•		•									TERMOMETRO	976188						•	•			•		•		•				TERMOMETRO	976188					•		•			•						10/05	0038	TAPPO COPRIVITE	502394				•		•	•		•							09/05		TAPPO COPRIVITE	502394				•		•	•		•									TAPPO COPRIVITE	65160108						•	•			•		•		•				TAPPO COPRIVITE	65160108						•	•			•		•				10/05	0044	FERMACAVO	573266				•		•	•		•		•		•		•		0045	VITE M6X12	993000				•		•	•		•		•		•		•		0050	CAVO ALIMENTAZIONE	993199				•		•	•		•		•		•		•			CAVO ALIMENTAZIONE	570086						•	•			•								CAVO ALIMENTAZIONE	570086						•	•			•						10/05	0068	GEMMA SPIA	976002				•		•	•		•		•		•		•		0071	PROTEZIONE FASTON ROSSO	993010				•		•	•		•		•		•		•		0084	BORCHIA TUBO USCITA ROSSA	502386						•	•			•						09/05	0085	BORCHIA TUBO ENTRATA BLU	502387						•	•			•						09/05																																																																																																																																																																																																																																																																																																																																																																																																																																																																																											
0028	VITI E TASSELLI	502379				•		•	•		•		•		•		•		0031	DADO ESAGONALE	570127				•		•	•		•		•		•		•		0033	GUARNIZIONE FLANGIA	570340				•		•	•		•								0035	TERMOMETRO	65160210				•		•	•		•									TERMOMETRO	976188						•	•			•		•		•				TERMOMETRO	976188					•		•			•						10/05	0038	TAPPO COPRIVITE	502394				•		•	•		•							09/05		TAPPO COPRIVITE	502394				•		•	•		•									TAPPO COPRIVITE	65160108						•	•			•		•		•				TAPPO COPRIVITE	65160108						•	•			•		•				10/05	0044	FERMACAVO	573266				•		•	•		•		•		•		•		0045	VITE M6X12	993000				•		•	•		•		•		•		•		0050	CAVO ALIMENTAZIONE	993199				•		•	•		•		•		•		•			CAVO ALIMENTAZIONE	570086						•	•			•								CAVO ALIMENTAZIONE	570086						•	•			•						10/05	0068	GEMMA SPIA	976002				•		•	•		•		•		•		•		0071	PROTEZIONE FASTON ROSSO	993010				•		•	•		•		•		•		•		0084	BORCHIA TUBO USCITA ROSSA	502386						•	•			•						09/05	0085	BORCHIA TUBO ENTRATA BLU	502387						•	•			•						09/05																																																																																																																																																																																																																																																																																																																																																																																																																																																																																																														
0031	DADO ESAGONALE	570127				•		•	•		•		•		•		•		0033	GUARNIZIONE FLANGIA	570340				•		•	•		•								0035	TERMOMETRO	65160210				•		•	•		•									TERMOMETRO	976188						•	•			•		•		•				TERMOMETRO	976188					•		•			•						10/05	0038	TAPPO COPRIVITE	502394				•		•	•		•							09/05		TAPPO COPRIVITE	502394				•		•	•		•									TAPPO COPRIVITE	65160108						•	•			•		•		•				TAPPO COPRIVITE	65160108						•	•			•		•				10/05	0044	FERMACAVO	573266				•		•	•		•		•		•		•		0045	VITE M6X12	993000				•		•	•		•		•		•		•		0050	CAVO ALIMENTAZIONE	993199				•		•	•		•		•		•		•			CAVO ALIMENTAZIONE	570086						•	•			•								CAVO ALIMENTAZIONE	570086						•	•			•						10/05	0068	GEMMA SPIA	976002				•		•	•		•		•		•		•		0071	PROTEZIONE FASTON ROSSO	993010				•		•	•		•		•		•		•		0084	BORCHIA TUBO USCITA ROSSA	502386						•	•			•						09/05	0085	BORCHIA TUBO ENTRATA BLU	502387						•	•			•						09/05																																																																																																																																																																																																																																																																																																																																																																																																																																																																																																																																	
0033	GUARNIZIONE FLANGIA	570340				•		•	•		•								0035	TERMOMETRO	65160210				•		•	•		•									TERMOMETRO	976188						•	•			•		•		•				TERMOMETRO	976188					•		•			•						10/05	0038	TAPPO COPRIVITE	502394				•		•	•		•							09/05		TAPPO COPRIVITE	502394				•		•	•		•									TAPPO COPRIVITE	65160108						•	•			•		•		•				TAPPO COPRIVITE	65160108						•	•			•		•				10/05	0044	FERMACAVO	573266				•		•	•		•		•		•		•		0045	VITE M6X12	993000				•		•	•		•		•		•		•		0050	CAVO ALIMENTAZIONE	993199				•		•	•		•		•		•		•			CAVO ALIMENTAZIONE	570086						•	•			•								CAVO ALIMENTAZIONE	570086						•	•			•						10/05	0068	GEMMA SPIA	976002				•		•	•		•		•		•		•		0071	PROTEZIONE FASTON ROSSO	993010				•		•	•		•		•		•		•		0084	BORCHIA TUBO USCITA ROSSA	502386						•	•			•						09/05	0085	BORCHIA TUBO ENTRATA BLU	502387						•	•			•						09/05																																																																																																																																																																																																																																																																																																																																																																																																																																																																																																																																																				
0035	TERMOMETRO	65160210				•		•	•		•									TERMOMETRO	976188						•	•			•		•		•				TERMOMETRO	976188					•		•			•						10/05	0038	TAPPO COPRIVITE	502394				•		•	•		•							09/05		TAPPO COPRIVITE	502394				•		•	•		•									TAPPO COPRIVITE	65160108						•	•			•		•		•				TAPPO COPRIVITE	65160108						•	•			•		•				10/05	0044	FERMACAVO	573266				•		•	•		•		•		•		•		0045	VITE M6X12	993000				•		•	•		•		•		•		•		0050	CAVO ALIMENTAZIONE	993199				•		•	•		•		•		•		•			CAVO ALIMENTAZIONE	570086						•	•			•								CAVO ALIMENTAZIONE	570086						•	•			•						10/05	0068	GEMMA SPIA	976002				•		•	•		•		•		•		•		0071	PROTEZIONE FASTON ROSSO	993010				•		•	•		•		•		•		•		0084	BORCHIA TUBO USCITA ROSSA	502386						•	•			•						09/05	0085	BORCHIA TUBO ENTRATA BLU	502387						•	•			•						09/05																																																																																																																																																																																																																																																																																																																																																																																																																																																																																																																																																																							
	TERMOMETRO	976188						•	•			•		•		•				TERMOMETRO	976188					•		•			•						10/05	0038	TAPPO COPRIVITE	502394				•		•	•		•							09/05		TAPPO COPRIVITE	502394				•		•	•		•									TAPPO COPRIVITE	65160108						•	•			•		•		•				TAPPO COPRIVITE	65160108						•	•			•		•				10/05	0044	FERMACAVO	573266				•		•	•		•		•		•		•		0045	VITE M6X12	993000				•		•	•		•		•		•		•		0050	CAVO ALIMENTAZIONE	993199				•		•	•		•		•		•		•			CAVO ALIMENTAZIONE	570086						•	•			•								CAVO ALIMENTAZIONE	570086						•	•			•						10/05	0068	GEMMA SPIA	976002				•		•	•		•		•		•		•		0071	PROTEZIONE FASTON ROSSO	993010				•		•	•		•		•		•		•		0084	BORCHIA TUBO USCITA ROSSA	502386						•	•			•						09/05	0085	BORCHIA TUBO ENTRATA BLU	502387						•	•			•						09/05																																																																																																																																																																																																																																																																																																																																																																																																																																																																																																																																																																																										
	TERMOMETRO	976188					•		•			•						10/05	0038	TAPPO COPRIVITE	502394				•		•	•		•							09/05		TAPPO COPRIVITE	502394				•		•	•		•									TAPPO COPRIVITE	65160108						•	•			•		•		•				TAPPO COPRIVITE	65160108						•	•			•		•				10/05	0044	FERMACAVO	573266				•		•	•		•		•		•		•		0045	VITE M6X12	993000				•		•	•		•		•		•		•		0050	CAVO ALIMENTAZIONE	993199				•		•	•		•		•		•		•			CAVO ALIMENTAZIONE	570086						•	•			•								CAVO ALIMENTAZIONE	570086						•	•			•						10/05	0068	GEMMA SPIA	976002				•		•	•		•		•		•		•		0071	PROTEZIONE FASTON ROSSO	993010				•		•	•		•		•		•		•		0084	BORCHIA TUBO USCITA ROSSA	502386						•	•			•						09/05	0085	BORCHIA TUBO ENTRATA BLU	502387						•	•			•						09/05																																																																																																																																																																																																																																																																																																																																																																																																																																																																																																																																																																																																													
0038	TAPPO COPRIVITE	502394				•		•	•		•							09/05		TAPPO COPRIVITE	502394				•		•	•		•									TAPPO COPRIVITE	65160108						•	•			•		•		•				TAPPO COPRIVITE	65160108						•	•			•		•				10/05	0044	FERMACAVO	573266				•		•	•		•		•		•		•		0045	VITE M6X12	993000				•		•	•		•		•		•		•		0050	CAVO ALIMENTAZIONE	993199				•		•	•		•		•		•		•			CAVO ALIMENTAZIONE	570086						•	•			•								CAVO ALIMENTAZIONE	570086						•	•			•						10/05	0068	GEMMA SPIA	976002				•		•	•		•		•		•		•		0071	PROTEZIONE FASTON ROSSO	993010				•		•	•		•		•		•		•		0084	BORCHIA TUBO USCITA ROSSA	502386						•	•			•						09/05	0085	BORCHIA TUBO ENTRATA BLU	502387						•	•			•						09/05																																																																																																																																																																																																																																																																																																																																																																																																																																																																																																																																																																																																																																
	TAPPO COPRIVITE	502394				•		•	•		•									TAPPO COPRIVITE	65160108						•	•			•		•		•				TAPPO COPRIVITE	65160108						•	•			•		•				10/05	0044	FERMACAVO	573266				•		•	•		•		•		•		•		0045	VITE M6X12	993000				•		•	•		•		•		•		•		0050	CAVO ALIMENTAZIONE	993199				•		•	•		•		•		•		•			CAVO ALIMENTAZIONE	570086						•	•			•								CAVO ALIMENTAZIONE	570086						•	•			•						10/05	0068	GEMMA SPIA	976002				•		•	•		•		•		•		•		0071	PROTEZIONE FASTON ROSSO	993010				•		•	•		•		•		•		•		0084	BORCHIA TUBO USCITA ROSSA	502386						•	•			•						09/05	0085	BORCHIA TUBO ENTRATA BLU	502387						•	•			•						09/05																																																																																																																																																																																																																																																																																																																																																																																																																																																																																																																																																																																																																																																			
	TAPPO COPRIVITE	65160108						•	•			•		•		•				TAPPO COPRIVITE	65160108						•	•			•		•				10/05	0044	FERMACAVO	573266				•		•	•		•		•		•		•		0045	VITE M6X12	993000				•		•	•		•		•		•		•		0050	CAVO ALIMENTAZIONE	993199				•		•	•		•		•		•		•			CAVO ALIMENTAZIONE	570086						•	•			•								CAVO ALIMENTAZIONE	570086						•	•			•						10/05	0068	GEMMA SPIA	976002				•		•	•		•		•		•		•		0071	PROTEZIONE FASTON ROSSO	993010				•		•	•		•		•		•		•		0084	BORCHIA TUBO USCITA ROSSA	502386						•	•			•						09/05	0085	BORCHIA TUBO ENTRATA BLU	502387						•	•			•						09/05																																																																																																																																																																																																																																																																																																																																																																																																																																																																																																																																																																																																																																																																						
	TAPPO COPRIVITE	65160108						•	•			•		•				10/05	0044	FERMACAVO	573266				•		•	•		•		•		•		•		0045	VITE M6X12	993000				•		•	•		•		•		•		•		0050	CAVO ALIMENTAZIONE	993199				•		•	•		•		•		•		•			CAVO ALIMENTAZIONE	570086						•	•			•								CAVO ALIMENTAZIONE	570086						•	•			•						10/05	0068	GEMMA SPIA	976002				•		•	•		•		•		•		•		0071	PROTEZIONE FASTON ROSSO	993010				•		•	•		•		•		•		•		0084	BORCHIA TUBO USCITA ROSSA	502386						•	•			•						09/05	0085	BORCHIA TUBO ENTRATA BLU	502387						•	•			•						09/05																																																																																																																																																																																																																																																																																																																																																																																																																																																																																																																																																																																																																																																																																									
0044	FERMACAVO	573266				•		•	•		•		•		•		•		0045	VITE M6X12	993000				•		•	•		•		•		•		•		0050	CAVO ALIMENTAZIONE	993199				•		•	•		•		•		•		•			CAVO ALIMENTAZIONE	570086						•	•			•								CAVO ALIMENTAZIONE	570086						•	•			•						10/05	0068	GEMMA SPIA	976002				•		•	•		•		•		•		•		0071	PROTEZIONE FASTON ROSSO	993010				•		•	•		•		•		•		•		0084	BORCHIA TUBO USCITA ROSSA	502386						•	•			•						09/05	0085	BORCHIA TUBO ENTRATA BLU	502387						•	•			•						09/05																																																																																																																																																																																																																																																																																																																																																																																																																																																																																																																																																																																																																																																																																																												
0045	VITE M6X12	993000				•		•	•		•		•		•		•		0050	CAVO ALIMENTAZIONE	993199				•		•	•		•		•		•		•			CAVO ALIMENTAZIONE	570086						•	•			•								CAVO ALIMENTAZIONE	570086						•	•			•						10/05	0068	GEMMA SPIA	976002				•		•	•		•		•		•		•		0071	PROTEZIONE FASTON ROSSO	993010				•		•	•		•		•		•		•		0084	BORCHIA TUBO USCITA ROSSA	502386						•	•			•						09/05	0085	BORCHIA TUBO ENTRATA BLU	502387						•	•			•						09/05																																																																																																																																																																																																																																																																																																																																																																																																																																																																																																																																																																																																																																																																																																																															
0050	CAVO ALIMENTAZIONE	993199				•		•	•		•		•		•		•			CAVO ALIMENTAZIONE	570086						•	•			•								CAVO ALIMENTAZIONE	570086						•	•			•						10/05	0068	GEMMA SPIA	976002				•		•	•		•		•		•		•		0071	PROTEZIONE FASTON ROSSO	993010				•		•	•		•		•		•		•		0084	BORCHIA TUBO USCITA ROSSA	502386						•	•			•						09/05	0085	BORCHIA TUBO ENTRATA BLU	502387						•	•			•						09/05																																																																																																																																																																																																																																																																																																																																																																																																																																																																																																																																																																																																																																																																																																																																																		
	CAVO ALIMENTAZIONE	570086						•	•			•								CAVO ALIMENTAZIONE	570086						•	•			•						10/05	0068	GEMMA SPIA	976002				•		•	•		•		•		•		•		0071	PROTEZIONE FASTON ROSSO	993010				•		•	•		•		•		•		•		0084	BORCHIA TUBO USCITA ROSSA	502386						•	•			•						09/05	0085	BORCHIA TUBO ENTRATA BLU	502387						•	•			•						09/05																																																																																																																																																																																																																																																																																																																																																																																																																																																																																																																																																																																																																																																																																																																																																																					
	CAVO ALIMENTAZIONE	570086						•	•			•						10/05	0068	GEMMA SPIA	976002				•		•	•		•		•		•		•		0071	PROTEZIONE FASTON ROSSO	993010				•		•	•		•		•		•		•		0084	BORCHIA TUBO USCITA ROSSA	502386						•	•			•						09/05	0085	BORCHIA TUBO ENTRATA BLU	502387						•	•			•						09/05																																																																																																																																																																																																																																																																																																																																																																																																																																																																																																																																																																																																																																																																																																																																																																																								
0068	GEMMA SPIA	976002				•		•	•		•		•		•		•		0071	PROTEZIONE FASTON ROSSO	993010				•		•	•		•		•		•		•		0084	BORCHIA TUBO USCITA ROSSA	502386						•	•			•						09/05	0085	BORCHIA TUBO ENTRATA BLU	502387						•	•			•						09/05																																																																																																																																																																																																																																																																																																																																																																																																																																																																																																																																																																																																																																																																																																																																																																																																											
0071	PROTEZIONE FASTON ROSSO	993010				•		•	•		•		•		•		•		0084	BORCHIA TUBO USCITA ROSSA	502386						•	•			•						09/05	0085	BORCHIA TUBO ENTRATA BLU	502387						•	•			•						09/05																																																																																																																																																																																																																																																																																																																																																																																																																																																																																																																																																																																																																																																																																																																																																																																																																														
0084	BORCHIA TUBO USCITA ROSSA	502386						•	•			•						09/05	0085	BORCHIA TUBO ENTRATA BLU	502387						•	•			•						09/05																																																																																																																																																																																																																																																																																																																																																																																																																																																																																																																																																																																																																																																																																																																																																																																																																																																	
0085	BORCHIA TUBO ENTRATA BLU	502387						•	•			•						09/05																																																																																																																																																																																																																																																																																																																																																																																																																																																																																																																																																																																																																																																																																																																																																																																																																																																																				



ELENCO ABBREVIAZIONI UTILIZZATE

EC	: Acqua calda.
EF	: Acqua fredda.
C	: Resistenza ceramica (Riscaldamento normale).
Ca	: resistenza ceramica (Riscaldamento accelerato).
TP	: Resistenza immersa.
1F	: Con rubinetteria.
2F	: Senza rubinetteria.
3F	: con rubinetteria e uscita complementare.
AMI	: Con miscelatore integrato.
SMI	: Senza miscelatore integrato.
PUISS	: Natura dell'apparecchio.
PN	: Apparecchio a pressione normale.
BP	: Apparecchio a bassa pressione.
PV	: Apparecchio a potenza variabile.
PF	: Apparecchio a potenza stabile.

TARGA MATRICOLA

NUMERO DI SERIE

Es: SI-V-0B0 45 07 0001

Codice sequenziale

Anno di fabbricazione : 6 → 2004

Mese di fabbricazione : 7 → 2005

8 → 2006

etc ...

25 → Gennaio

13 → Febbraio

32 → Marzo

35 → Aprile

39 → Maggio

45 → Giugno

43 → Luglio

29 → Agosto

40 → Settembre

38 → Ottobre

51 → Novembre

12 → Dicembre

I dati presenti sulla tariffa e le documentazioni commerciali o tecniche, gli schemi e altre informazioni sono dati a titolo indicativo e validi per un certo periodo. Il COSTRUTTORE si riserva la facoltà di modificare la presentazione, la forma, la dimensione, la concezione o la materia dei suoi prodotti.